

INSTRUCTION MANUAL

RPB[®]
PX5[®] PAPR



EMPLOYERS: Read this manual and the respirator head-top Instruction Manual and carry out the Employer Responsibilities (page 5).

PRODUCT USERS: Read this manual and the respirator head-top Instruction Manual and follow the Product User Safety Instructions (page 7).

Manuals are regularly updated. Make sure this manual is available to all users for reference.

Current version of this manual and other languages:
rpbsafety.com/air-monitoring-filtration-supply/px5

The Respiratory Protection **Brand**®



CONTENTS

■ EXPLANATION OF SIGNAL WORDS AND SYMBOLS	2
■ INTRODUCTION	3
■ IMPORTANT SAFETY INFORMATION	
□ PROTECTION PROVIDED AND LIMITATIONS	4
□ EMPLOYER RESPONSIBILITIES	5
□ PRODUCT USER SAFETY INSTRUCTIONS	7
□ RESPIRATORY COMPONENT DIAGRAM - NIOSH CAUTIONS & LIMITATIONS	10
■ RESPIRATOR SETUP AND CARE	12
■ ALARMS	22
■ INSPECTION AND CLEANING	26
■ PRODUCT SPECIFICATIONS AND DATA	28
■ PARTS AND ACCESSORIES	29
■ WARRANTY AND LIABILITY STATEMENT	30

EXPLANATION OF SIGNAL WORDS AND SYMBOLS

The following signal word and safety symbols are used in this manual and product labeling:



WARNING indicates a hazardous situation that, if not avoided, could result in death or serious injury.



Read the Instruction Manual.

Additional copies of RPB® manuals can be found at www.rpbsafety.com.

RPB® Safety LLC is an ISO9001 certified company.

INTRODUCTION

The RPB® PX5® is approved by NIOSH as a Powered Air Purifying Respirator Fan Unit designed to be used in conjunction with the approved RPB® head-tops. The RPB® PX5® is for applications where there is a need for protection from airborne contaminants such as welding, grinding, painting, construction and other industrial applications, as well as pharmaceutical manufacturing. The PX5® is tested to IP 65 for water and dust ingress while in operation.

This product must be inspected and maintained in accordance with this instruction manual at all times.

See PROTECTION PROVIDED AND LIMITATIONS (page 4) for details.

RPB® SAFETY - GLOBAL HEADQUARTERS

2807 Samoset Rd, Royal Oak, MI 48073, USA.

T: 1-866-494-4599 F: 1-866-494-4509 E: sales.us@rpbsafety.com **rpbsafety.com**

RPB® SAFETY - APAC

1 Ivan Jamieson Place, Christchurch Airport, Christchurch 8053 New Zealand.

T: +64-3-357-1761 F: +64-3-357-1763 E: sales.nz@rpbsafety.com **rpbsafety.com**

RPB® SAFETY - EMEA

Unit 2, Teardrop Industrial Park, London Road, Swanley, BR8 8TS, United Kingdom

T: +44-800-689-5031 E: sales@rpbsafety.co.uk **rpbsafety.com**

Copyright ©2019 RPB Safety, LLC. All rights reserved. All materials contained on this website are protected by United States copyright law and may not be reproduced, distributed, transmitted, displayed, published or broadcast without the prior written permission of RPB Safety, LLC. You may not alter or remove any trademark, copyright or other notice from copies of the content.

All trademarks, service marks, and logos used in this publication, both registered and unregistered, are the trademarks, service marks, or logos of their respective owners. All rights in the RPB Intellectual Property contained in this publication, including copyright, trademarks, service marks, trade secret, and patent rights are reserved. RPB Intellectual Property means any patent, patented articles, patent applications, designs, industrial designs, copyrights, software, source code, database rights, moral rights, inventions, techniques, technical data, trade secrets, know-how, brands, trademarks, trade names, slogans, logos, and any other common law and proprietary rights, whether registered or unregistered anywhere in the world, that are owned by, developed in whole or in part by, or licensed by RPB Safety, LLC. For technical assistance contact our Customer Service Department at 1-866-494-4599 or email: customerservice@rpbsafety.com

Form #: 7.20.568

Rev: 0

IMPORTANT SAFETY INFORMATION

WARNING

Improper selection, fit, use, or maintenance of this product can result in injury; life threatening delayed lung, skin or eye disease; or death.

This product is intended for occupational use in accordance with applicable standards or regulations for your location, industry, and activity (see Employer Responsibilities, page 5). Familiarity with standards and regulations related to the use of this protective equipment is recommended, even if they do not directly apply to you. If self-employed or if used in a non-occupational setting, refer to Employer Responsibilities and Product User Safety Instructions. Go to rpb.com/safety/importantsafetyinformation/ for helpful links to OSHA and other content.

EMPLOYERS: Read this manual and the respirator head-top Instruction Manual and carry out the Employer Responsibilities (page 5).

PRODUCT USERS: Read this manual and the respirator head-top Instruction Manual and follow the Product User Safety Instructions (page 7).

CHECK WEBSITE FOR UPDATES. Product manuals are regularly updated.

Visit www.rpbsafety.com/resources/ for the most recent version of this manual before using the product.

PROTECTION PROVIDED AND LIMITATIONS

RESPIRATION

The RPB® PX5® is approved by NIOSH in the categories as follows:

Powered Air

The RPB® PX5® PAPR, when properly fitted and used with all required components, including the Breathing Tube Assembly and the approved head top, is part of a NIOSH approved powered air purifying respirator. As such, it significantly reduces, but does not completely eliminate, the breathing of contaminants by the respirator wearer. See the instruction manual and approval label for the selected head top for NIOSH approval with the PX5® and the assigned protection factor. Specific protection depends on the filter selected for use in the RPB® PX5® PAPR. It is approved to be used with the O3-892 High Efficiency (HE) Filter.

HAZARD LIMITATIONS

The RPB® PX5® PAPR is **NOT FOR USE** if:

- In atmospheres immediately dangerous to life or health (IDLH).
- Wearer cannot escape without the aid of the respirator.
- Atmosphere contains less than 19.5% oxygen.
- In abrasive blasting applications.
- For protection against hazardous gases (e.g., carbon monoxide).
- Contaminants are in excess of regulations or recommendations.
- Contaminants or contaminant concentrations are unknown.
- Work area is poorly ventilated.

- The temperature is outside the range of -4°F to 122°F (-20°C to +50°C). If the internal battery temperature reaches 140°F (60°C) the unit will completely shut down.
- Flammable or explosive atmosphere is present. This system contains electrical parts that are not suitable for use in such environments. The PX5® is not intrinsically safe.

AIR SOURCE

Powered Air

Check that the contaminated area is within the limits of use for a Powered Air Purifying Respirator and determine the type of contamination. Once the contamination level has been confirmed you can then determine the filter cartridge to be used for the application, to make sure that you are sufficiently protected. Make sure that the area is well ventilated and that regular air samples are taken to confirm the atmosphere stays within the levels recommended by OSHA and other governing bodies.

EMPLOYER RESPONSIBILITIES

Your specific responsibilities may vary by location and industry, but in general RPB® expects that employers will:

- **Follow all applicable standards and regulations for your location, industry, and activity.**

Depending on your location and industry, a number of standards and regulations may apply to your selection and use of respirators and other personal protective equipment. These may include such things as federal (e.g., OSHA, MSHA, Canadian Occupational Health and Safety), local (e.g., state, provincial), or military standards and regulations and consensus standards such as ANSI and CSA. There are also requirements specific to particular contaminants, e.g. silica (see rpbsafety.com for more information), asbestos, organic pathogens, etc. Know which requirements apply to your location and industry.

- **Have appropriate safety programs in place.**

Have and follow:

- A workplace safety program.
- A written respiratory protection program in accordance with applicable standards and regulations (e.g., OSHA 29 CFR 1910.134; ANSI/ASSE Z88.2; CSA Z94.4, etc.).

- **In accordance with the above,**

- Perform a hazard analysis and select appropriate equipment for each activity.** A hazard analysis should be performed by a qualified person. Controls should be in place as appropriate and a qualified person should determine what kind of respiratory, face and eye, head, and hearing protection is appropriate for the intended activities and environments of use. (For example, select a respirator appropriate to the specific airborne hazards, with consideration of workplace and user factors and with an Assigned Protection Factor (APF) that meets or exceeds the required level for employee protection,

EMPLOYER RESPONSIBILITIES CONTINUED

select welding face and eye protection appropriate to the type of welding to be done, etc.)

As applicable, check your workplace safety program, respiratory protection program, and standards and regulations for your activity or industry for related protection requirements, and see this manual (Protection Provided and Limitations, page 4) and the head top Instruction Manual for product specifications.

Be sure employees are medically qualified to use a respirator.

Have a qualified physician or other licensed health care professional (PLHCP) perform medical evaluations using a medical questionnaire or an initial medical examination per OSHA 29 CFR 1910.134.

Train employees in the PX5®'s use, maintenance, and limitations.

Appoint a qualified individual who is knowledgeable about the RPB® PX5® per ANSI/ASSE Z88.2 guidelines to provide training:

8.1 Qualifications of the Respirator Trainer. Anyone providing respirator training shall:

- a) be knowledgeable in the application and use of the respirator(s);
- b) have practical knowledge in the selection and use of respirator(s) and work practices at the site;
- c) have an understanding of the site's respirator program; and
- d) be knowledgeable of applicable regulations.

Train each PX5® user in the product's use, application, inspection, maintenance, storage, fitting, and limitations in accordance with the content of this Instruction Manual and the approved head top Instruction Manual and standard or regulatory requirements. Ensure that each intended user reads both these manuals.

Ensure that equipment is properly set up, used, and maintained.

Make sure that equipment is properly set up, inspected, used, and maintained, including selection of the appropriate air filter cartridge for the application.

Measure and monitor airborne contaminants in the work area.

Measure and monitor airborne contaminant levels in the work area in accordance with applicable requirements. Make sure work area is well ventilated.

■ **Exposure limits for mixtures:**

The American Conference of Government Industrial Hygienists (ACGIH) publishes a Guide to Occupational Exposure Values and also documentation for Threshold Limit Values and Biological Exposure Indices.

The information supplied by ACGIH provides formulas and information to calculate the exposure level of the atmosphere. This helps to determine the appropriate respirator category required for protection against all contaminants present. Check the ACGIH publications to help determine the right protection for your application.

■ **If you have any questions, contact RPB®.**

- Call Customer Service Department at:
Tel: 1-866-494-4599 or
E-mail: customerservice@rpbsafety.com
Web: rpbsafety.com

PRODUCT USER SAFETY INSTRUCTIONS

BEFORE INITIAL USE - BE TRAINED AND MEDICALLY QUALIFIED

Do not use this device until you have read this manual and the approved head top Instruction Manual (additional copies available at www.rpbsafety.com) and have been trained in the respirator's use, maintenance, and limitations by a qualified individual (appointed by your employer) who is well informed and understands the RPB® PX5® PAPR.

Do not wear this respirator until you have passed a medical evaluation using a medical questionnaire or an initial medical examination by a qualified physician or other licensed health care professional (PLHCP).

Allergens: No known common allergens are used in this product.

Some materials could cause an allergic reaction in susceptible individuals. If you have a known allergy or develop irritation, inform your employer. Irritation may occur from lack of cleaning. Follow all cleaning and care instructions provided in the instruction manuals for this and any other RPB® products you are using.

MAKE SURE THE SYSTEM IS READY FOR USE

Make sure you have a complete system. The PX5® is only one component of a NIOSH approved respirator system. Verify that you have all required components for the PX5® to serve as a complete NIOSH approved respirator:

- Respirator Head-top Assembly approved with the PX5®
- Breathing Tube Assembly
- PX5® PAPR

See Respirator Component Diagram (page 10). See the instruction manual and approval label for the selected head top for NIOSH approval with the PX5® and the assigned protection factor. Use only authentic RPB® brand parts and components that are part of the NIOSH approved respirator assembly. Using incomplete or inappropriate equipment, including the use of counterfeit or non-RPB® parts, can result in inadequate protection and will void the NIOSH approval of the entire respirator. Do not modify or alter any part of this product.

Inspect all components daily for signs of damage or wear and tear that may reduce the level of protection originally provided, see Inspection and Cleaning (p. 26) for details. Remove any damaged component or product, including any belt, breathing tube, battery door, seals, or front cover of the PAPR, from service until repaired or replaced. Damaged components should be replaced with genuine RPB® brand replacement parts. Replace HE filter when they are visually dirty, filter media is damaged, or the airflow is reduced. Inspect the prefilter and the spark arrestor

PRODUCT USER SAFETY INSTRUCTIONS CONTINUED

for damage or blockage. Inspect the inside of the respirator for respirable dust or other foreign objects. Keep the inside of the respirator clean at all times.

Make sure that the PAPR is correctly assembled in the configuration that suits your application. Never use the respirator without a HE filter in place depending on the application. It is recommended that a prefilter always be used. For applications that produce sparks or high heat, use the FR (Fire Retardant) specific model of the PX5® with the FR belt and spark arrester. The PX5® must always be used with the correct filter(s), the front cover and the cowl to form a complete system, unless otherwise specified. An incomplete system could provide inadequate respiratory protection. See *Respirator Setup and Care* (page 12).

VERIFY THAT YOU HAVE THE APPROPRIATE EQUIPMENT FOR YOUR ACTIVITY

Verify that the PX5® provides appropriate protection for your activity. When applicable, check your workplace safety program, respiratory protection program, and standards and regulations for your activity or industry. (See PROTECTION PROVIDED AND LIMITATIONS, page 4.)

BEFORE DONNING THE PX5®:

Verify airborne contaminants are within recommended limits for respirator use:

- Determine the type and level of contamination. Verify that airborne contaminant concentrations do not exceed those allowed by applicable OSHA, EPA, or NIOSH regulations and recommendations for powered air purifying respirators or supplied air respirators.

Select the correct filter cartridge for the contamination and application:

- **PAPR:** Once the contamination level has been confirmed, determine the correct filter cartridge to be used for the application, to make sure that you are sufficiently protected.

Make sure the area is ventilated and monitored:

- Make sure that the area is well ventilated and that regular air samples are taken to confirm the atmosphere stays within the levels recommended by OSHA and other governing bodies.

If you have any questions, ask your employer.

DO NOT ENTER THE WORK AREA if any of the following conditions exist:

- Atmosphere is immediately dangerous to life or health.
- You cannot escape without the aid of the respirator.
- Atmosphere contains less than 19.5% oxygen.
- If flammable or explosive atmosphere is present. This system contains electrical parts that are not suitable for use in such environments. The PX5® is not intrinsically safe.
- Contaminants are in excess of regulations or recommendations.
- Contaminants or contaminant concentrations are unknown.
- Work area is poorly ventilated.
- The work area is a confined space (unless proper measures are taken).
- The temperature is outside the range of -4°F to 122°F (-20°C to +50°C)

LEAVE THE WORK AREA IMMEDIATELY IF:

- Any product component becomes damaged.
- Vision is impaired.
- Airflow stops or slows down, or alarm sounds. Do not use Powered Air Purifying Respirators if airflow is less than 6 cfm (170 slpm).
- Breathing becomes difficult.
- You become dizzy, nauseous, too hot, too cold, or ill.
- Your eyes, nose, or skin become irritated.
- You taste, smell, or see contaminants inside the helmet.
- You have any other reason to suspect that the respirator is not providing adequate protection.

PRODUCT CARE

Never place the PX5® on hot surfaces. Do not apply paints, solvents, adhesives or self-adhesive labels except as instructed by RPB®. This product may be adversely affected by certain chemicals.

See the "Inspection and Cleaning" section for cleaning instructions.

INSTRUCTIONS FOR SPECIFIC USES OR ENVIRONMENTS**Welding and Grinding**

For welding, grinding, and other applications that produce sparks or high heat, be sure to use the FR (Fire Retardant) specific model of the PX5® with the FR belt and spark arrestor in place, see "Respirator Setup and Care" (page 12).

Confined Spaces

If this respirator is used in confined spaces, ensure the area is well ventilated and that all contaminant concentrations are below those recommended for this respirator. Follow all procedures for confined space entry, operation, and exit as defined in applicable regulations and standards.

Welding in Confined Spaces

Welding in a confined space can present an atmospheric hazard due to the generation of contaminants and displacement of oxygen. A pressure-demand SCBA or a multifunctional pressure-demand supplied-air respirator with self-contained air supply shall be used during welding in confined spaces when welding can reduce the ambient oxygen level and supplemental ventilation and atmospheric monitoring are not provided according to 29 CFR 1910.146 and ANSI/ASSE Z117.1. For more information on respirator types refer to annex A.2 of ANSI/ASSE Z88.

RESPIRATOR COMPONENT DIAGRAM

The RPB® PX5® is one component of the three main components that constitute a powered air purifying respirator. (Note the T-Link® has been used in the diagram as an example.)

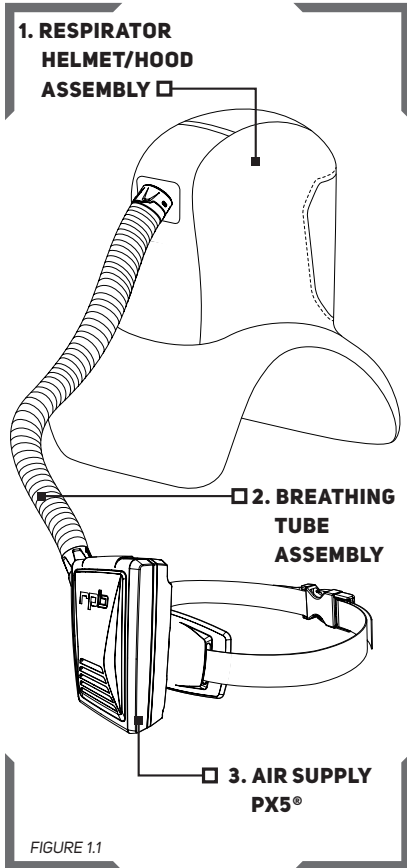

NIOSH - CAUTIONS AND LIMITATIONS

POWERED AIR

- A. Not for use in atmospheres containing less than 19.5 percent oxygen.
- B. Not for use in atmospheres immediately dangerous to life or health.

- C. Do not exceed maximum use concentrations established by regulatory standards.
- F. Do not use powered air-purifying respirators if airflow is less than four cfm (115 lpm) for tight fitting face pieces or six cfm (170 lpm) for hoods and/or helmets.
- H. Follow established cartridge and canister change schedules or observe ESLI to ensure that cartridge and canisters are replaced before breakthrough occurs.
- I. Contains electrical parts that may cause an ignition in flammable or explosive atmospheres.
- J. Failure to properly use and maintain this product could result in injury or death.
- L. Follow the manufacturer's User's Instructions for changing cartridges, canister and/or filters.
- M. All approved respirators shall be selected, fitted, used and maintained in accordance with MSHA, OSHA, and other applicable regulations.
- N. Never substitute, modify, add or omit parts. Use only exact replacement parts in the configuration as specified by the manufacturer.
- O. Refer to user's instructions, and/or maintenance manuals for information on use and maintenance of these respirators.
- P. NIOSH does not evaluate respirators for use as surgical masks.

RESPIRATOR SETUP AND CARE

BATTERY PACK



WARNING

To reduce the risk of battery fire, explosion, fire, or electric shock with the charger, follow these precautions and procedures:

Before charging

- Allow the battery to cool before charging if it feels hot.
- Inspect the battery pack before every charge. If there are any cracks or damage do not charge the battery pack.
- Inspect the charger and power cords before use. Replace if any parts are damaged. Do not substitute, modify or add parts to the chargers. Do not attempt to service the chargers. There are no user-serviceable parts inside.
- Use only the provided charger and cord.

Where to charge

Charge only:

- indoors,
- in a dry area,
- away from sources of heat,
- away from anything that can burn if exposed to heat or flame,
- in a well-ventilated place,
- where the charger can be monitored and easily observed during charging.

Battery care

- Do not use the battery outside the recommended temperature limits -4°F to 122°F (-20°C to +50°C).
- Do not charge the battery outside the recommended temperature limits 32° F to 113° F (0° C to 45° C).
- Do not store the battery outside the recommended temperature limits -4° F to 104° F (-20° C to 40° C).

Do not disassemble or immerse the battery or charger in water or other liquids.

The battery can short if the contacts are accidentally connected by metal other than the PX5® or the charger. To reset the battery, place the battery on the charging station. The battery will be ready to use again. While measures have been taken to protect the battery, damage can still occur, so be careful not to short any contacts together.

For mounting battery chargers to DIN rail, purchase the desired length from any electrical supply company "Top Hat Rail IEC/EN 60715" 35mm tall. 7.5 or 15 mm depth rail can be used. See "INSTALL BATTERY CHARGER ON A WALL" section for more instructions.

Disposal

Dispose of battery packs according to local regulations. Do not crush, disassemble, dispose of in standard waste bins, in a fire, or send for incineration. Failure to properly dispose of battery packs may lead to environmental contamination, fire or explosion.

RESPIRATOR SETUP AND CARE CONTINUED

CHARGING THE BATTERY PACK

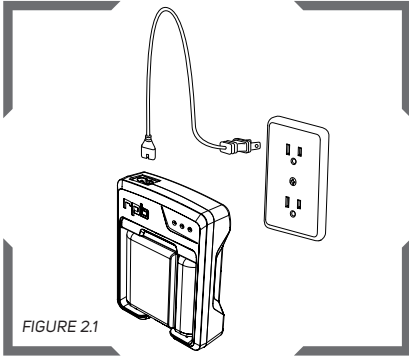

FIGURE 2.1

Connect the power cord to the charging station. Connect the other end of the power cord to the electrical source (110-240v).

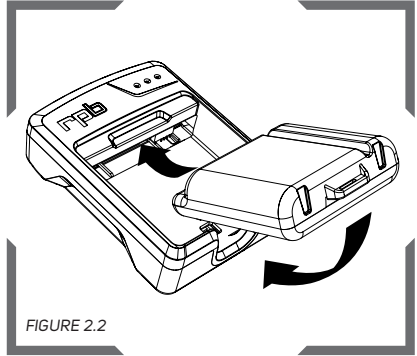

FIGURE 2.2

Fit the battery into the charging station by sliding the top of the battery into the charger housing and then rotate the battery down until it clicks into place.

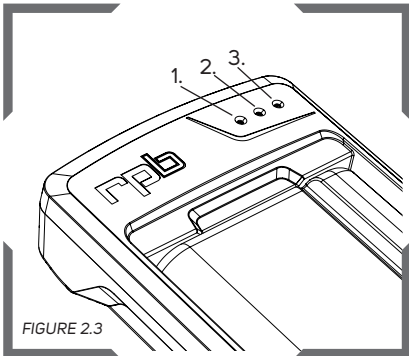

FIGURE 2.3

Follow the indicator lights on the top right corner of the charging station to know the status of the charge process. 1 blinking LED = low charge. 2 blinking LEDs = medium charge, 3 blinking LEDs = high charge, 3 solid LEDs = fully charged, approx. 95-100% charged.

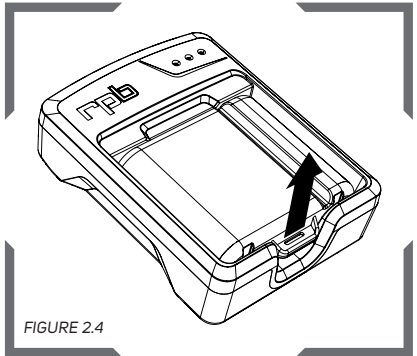
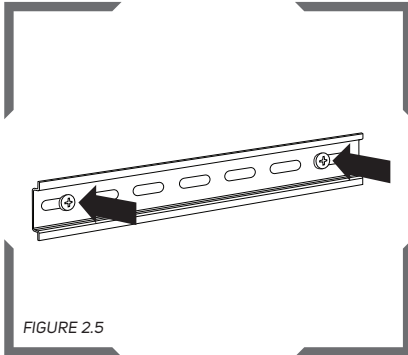

FIGURE 2.4

To remove the battery from the charging station, grip the charger housing firmly if not fixed in place, pull up on the tab on the bottom of the battery and slide the battery from the charger housing.

INSTALL BATTERY CHARGER ON A WALL



Using a desired length of DIN rail, depending on how many chargers you want to mount to it. Screw the DIN rail into the desired location for charging. Ensure the location of this mount meets those specified in the recommendations on page 11.

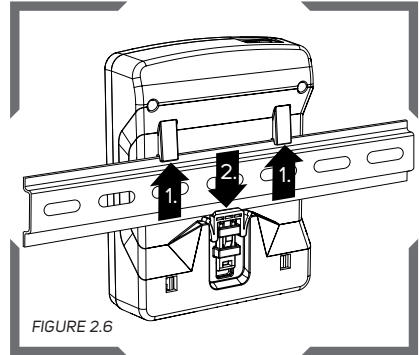

Hook the battery charger using the small tabs on the back over the top edge of the DIN rail (1.) and then rotate it down until it clicks over the bottom edge of the DIN rail (2.). The bottom tab should return to the resting location. Pull gently to test.

MULTIPLE CHARGERS ONTO A DIN RAIL

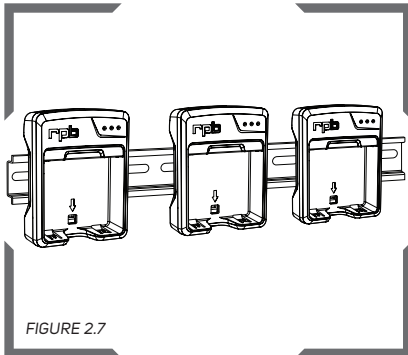

If required, multiple chargers can be mounted onto the DIN rail as per figure 2.6.

REMOVE CHARGER FROM DIN RAIL

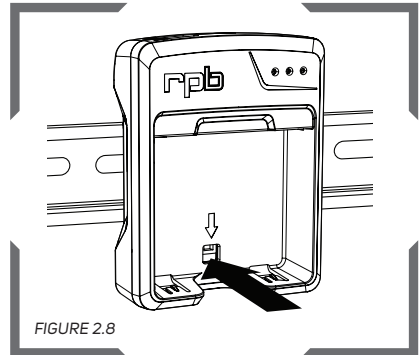

Remove the charger from the DIN rail using a flat head screw driver. Pull down the tab inside the cutout in the charger to release the clip from the DIN rail. Pull the charger from the DIN rail at the bottom and then lift the charger off.

RESPIRATOR SETUP AND CARE CONTINUED

INSTALL THE BATTERY PACK

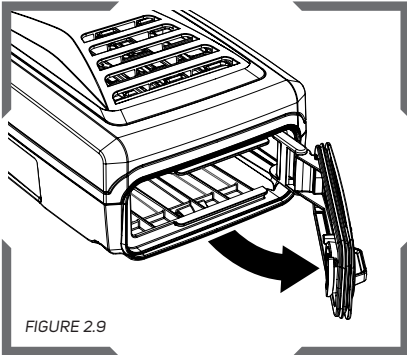

FIGURE 2.9

To insert the battery into the PX5®, open the battery compartment door on the bottom of the unit by twisting the knob to “unlocked”.

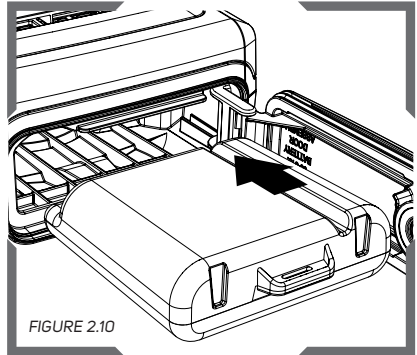

FIGURE 2.10

Slide the battery into the battery compartment of the PX5® by lining up the slot on the battery with the guide on the inside of the unit.

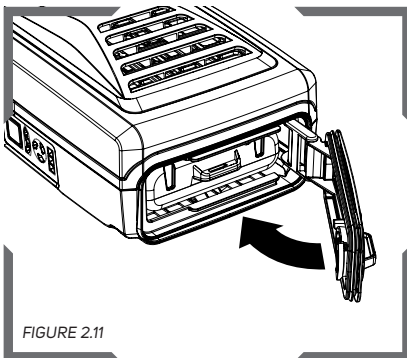

FIGURE 2.11

Close the battery compartment door, making sure the seal around the door properly seats and the latch securely engages. The door must be completely closed and sealed for the IP 65 rating and to protect the unit from damage from liquids or debris.

CHANGE BATTERY DOOR SEAL

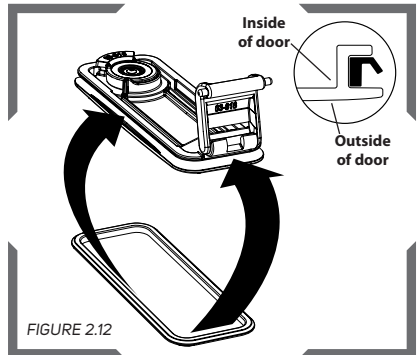
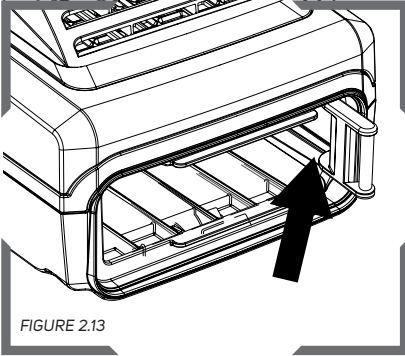

FIGURE 2.12

With the battery door off or open, remove the old seal. Note the orientation of the lip on the seal. Place the new seal into position by stretching it around the door, into the channel around the edge of the door.

REPLACE THE BATTERY DOOR HINGE



Remove the battery door, then slide the hinge back into the unit to remove it from the track inside of the battery compartment.

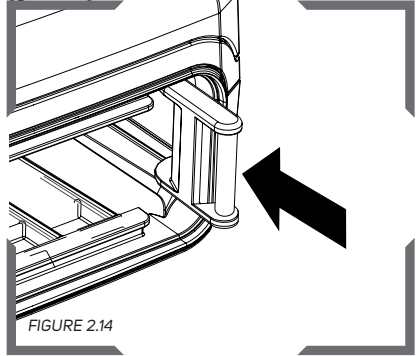

Slide the new hinge into the battery compartment with the pegs on the hinge in the tracks. Then snap the battery door onto the hinge crossbar.

REPLACE THE BATTERY DOOR

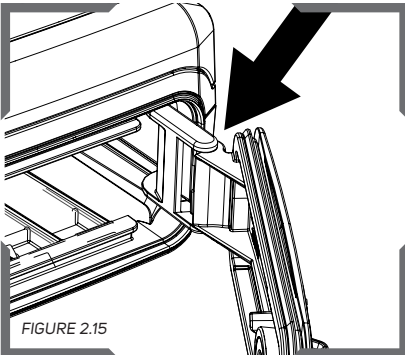

Disconnect the door from the hinge by pulling the door in the direction of the hinge opening. Attach the new door by snapping the door onto the hinge cross bar.

RESPIRATOR SETUP AND CARE CONTINUED

FILTERS

High Efficiency (HE) Filter

Use the O3-892 HE filter in atmospheres that contain only solid or liquid particulates, such as dusts, mists, or fumes.



WARNING

The HE filter does not remove organic vapors or acid gases.

Before unpacking the O3-892 HE filter, make sure that the sealed plastic packaging is still intact. Once the seal is broken the filter is exposed to the environment and may become contaminated. Before inserting the filter make sure that the following points are checked:

1. Check the PAPR is turned off and the fan is not running before opening the door of the unit.
2. Inspect the filter for tears or any sign of damage to the filter media.
3. Inspect the seal on the back side of the filter is clean and free of cuts or distortions.

Some substances, such as carbon monoxide, can not be filtered out with a PAPR and may require supplied air or SCBA.

Service Life of HE Filter, Prefilter and Spark Arrestor

The HE filter should be replaced if the airflow alarm is activated, or the flow indicator reading falls below the 6cfm (170 slpm) minimum airflow. The HE filter should also be replaced if there is damage to the filter media, such as a tear or puncture, etc., or the filter media becomes wet. The PX5® is approved to only be used with genuine RPB® filters and cartridges.

The Prefilter is recommended to be replaced when it is dirty or damaged or at the same time as the HE Filter. The Spark Arrestor should be replaced if it becomes damaged or clogged with debris.

TO INSTALL THE HIGH EFFICIENCY FILTER AND PREFILTER

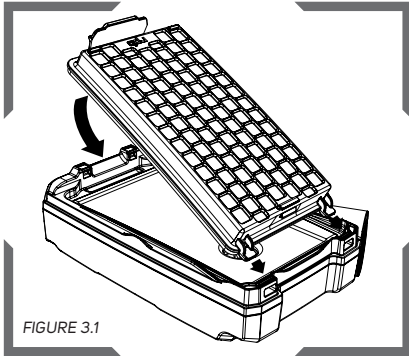

FIGURE 3.1

Mount the O3-892 HE Filter into the PX5[®] by placing the tabs through the slots in the top edge of the PX5[®] filter area and rotate the filter down until the bottom tab snaps into place. Check that both tabs on the filter latch are secure.

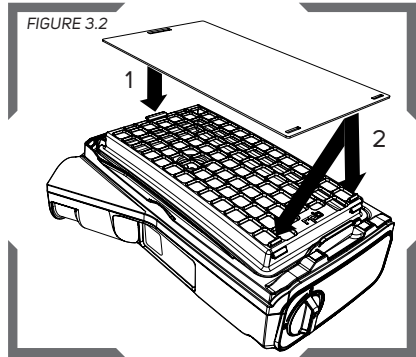

FIGURE 3.2

The prefilter can be attached to the HE Filter before or after the filters are installed onto the PAPR. Secure the prefilter onto the top tab (1.) on the HE filter and then over the bottom tabs (2.) on the bottom of the HE filter.

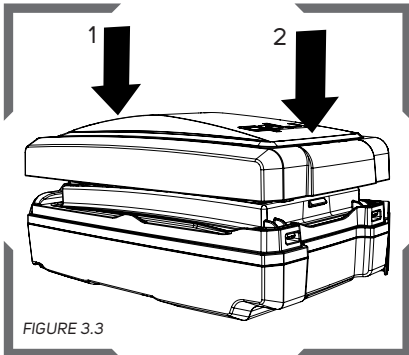

FIGURE 3.3

Orient the filter door with the handle cutout towards the top, opposite the battery door. Reattach the filter door by placing the door over the unit with filter in place and pressing on top (1) and bottom (2) until firm. You should hear a click and there should be little to no gap visible when clipped.

⚠ WARNING The PX5[®] filter doors will not attach without a filter in place. Never use the PAPR without a filter in place.

RESPIRATOR SETUP AND CARE CONTINUED

TO INSTALL/REPLACE THE SPARK ARRESTOR

FIGURE 4.1

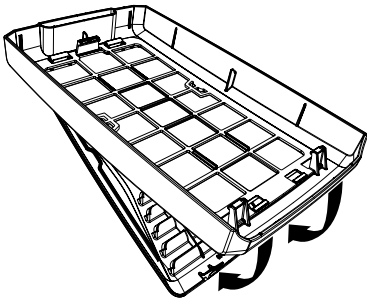

Remove the green spark arrester cover by removing the filter door and then pushing up on the tabs that hold the spark arrester cover in place.

FIGURE 4.2

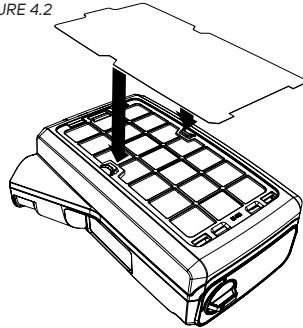

Place the filter door back onto the the PX5®. Secure the spark arrester under the tabs on the front of the filter door.

FIGURE 4.3

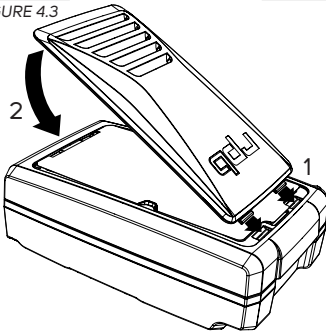

Reattach the spark arrester cover by rotating the tabs on the top into the slots in the filter door (1). Rotate the cover down until it clips in securely at the bottom (2).

FILTER REMOVAL

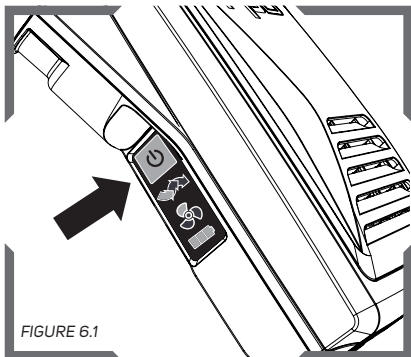

FIGURE 6.1

Make sure the PX5® fan unit is turned off before opening the Filter Door. (Note: Press and hold button to power off.) If the unit is on, contaminants may get pulled into the unit and the suction may make it hard to remove the filter.

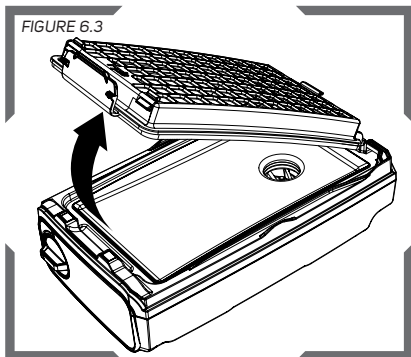

FIGURE 6.3

Remove the filter from the PX5® by pressing on the tab at the bottom end of the filter and lift up. Dispose of it in a responsible and safe manor in accordance with regulations. Install new filter and inspect/replace O3-890 prefilter.

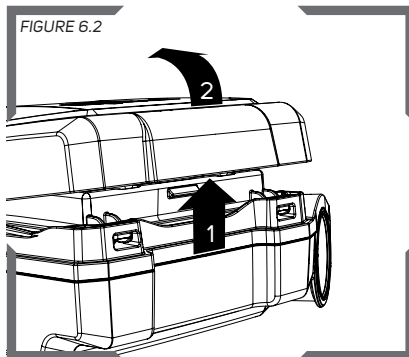

FIGURE 6.2

(1.) Lift up the back edge of the top of the filter door, (2.) rotate the door up and remove.

⚠ WARNING Depending on the contaminants filtered by the PX5®, the used filter itself may be hazardous. Take appropriate precautions when handling to avoid exposure to released contaminants; a company disposal procedure may be needed.

RESPIRATOR SETUP AND CARE CONTINUED

BREATHING TUBE

FIGURE 7.1

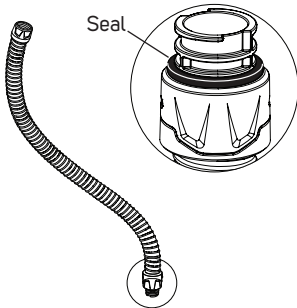

Inspect the breathing tube (04-831) and ensure there is no damage and that the o-rings are in place and in good condition.

FIGURE 7.2

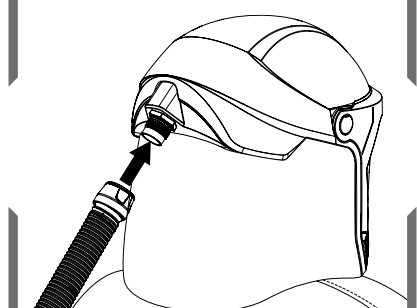

Screw the threaded end onto the inlet of the respirator.

FIGURE 7.3

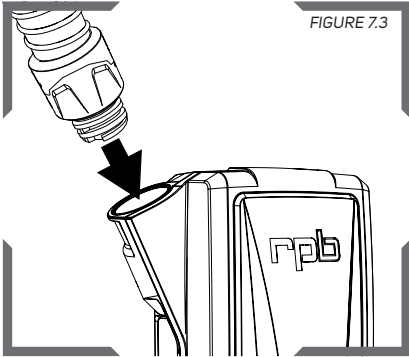

Take the bayonet end, insert the connection into the PX5® and make sure the slots line up with the pegs in the PX5® outlet.

FIGURE 7.4

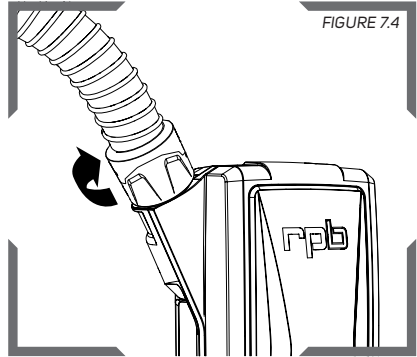

Twist the breathing tube clockwise 1/2 turn to lock into position. Make sure that it is fully locked in position.

POWER BUTTON AND BATTERY INDICATION

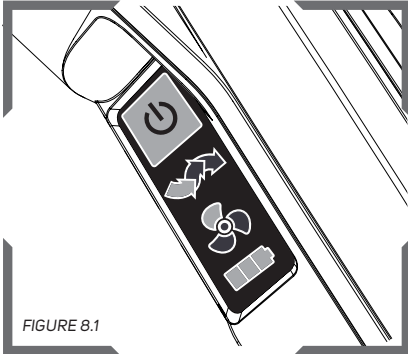

FIGURE 8.1

The power button is on the left side of the unit as you look at the front of the PX5®. **POWER ON:** Press and hold the power button (for about 1 second). The unit will vibrate and make an audible beep on start-up. Note the unit will always start up in the low speed setting and should reach nominal flow within 5-10 seconds. Allow the unit to warm up for 5 minutes or until the flow meter (03-819) is in the safe range before use, so that there is sufficient air flow. (See the Flow Tube section for how to read the measurement.)

POWER OFF: Press and hold the power button (for about 1 second) and the unit will turn off.

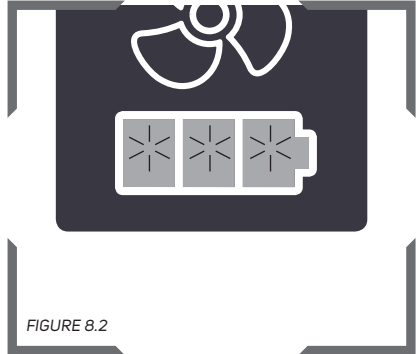

FIGURE 8.2

The battery level is indicated by the battery shaped LED panels on the side of the PX5®. 3 green LEDs = fully charged, 2 green LEDs = 25-75% charged, 1 green LED = less than 25% charged, 1 red LED blinking = 5% or less charge remaining, the battery needs to be charged and is about to turn off.

⚠ WARNING

When the alarm sounds it is recommended that you leave the work area immediately. Do not remove the respirator, remove the filter, or disconnect the breathing tube while in the work area. Once outside of the work area power the unit down and resolve the problem.

RESPIRATOR SETUP AND CARE CONTINUED

FAN SPEED

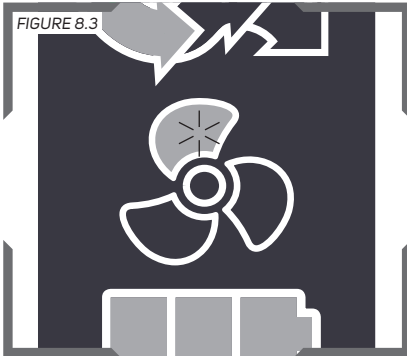

Speed Settings: Cycle through the 3 speed settings by pressing the Power Button. Each short button press will advance through these speed settings.

FILTER BLOCKAGE

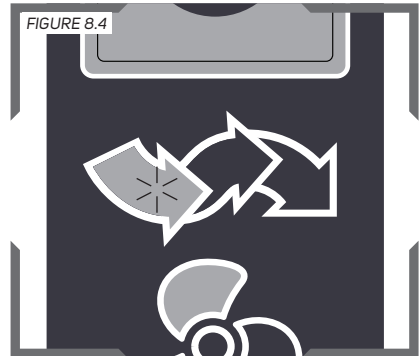

Filter blockage is indicated on the User Interface Panel by the multi-colored arrow under the power button. Green = full airflow, Yellow = mild blockage, reduced airflow, Red = blocked airflow. When the Red arrow is lit, safely exit the work area and check for any blockages in the air path. If blockage is not resolved, follow the filter change instructions.

ALARMS TABLE 1.1

<p>LOW AIRFLOW ALARM</p>	<p>A continuous alarm sounds when the airflow to the hood falls below the minimum requirement of 6cfm (170slpm) for more than 5-10 seconds in duration. Leave the work area to check the filter for blockage or anything obstructing the air path to the head-top. If the filter is blocked due to contaminants, replace the filter with a new one.</p>
<p>LOW BATTERY CHARGE ALARM</p>	<p>A pulsing alarm sounds when approximately 10-15 minutes of charge is left in the battery. Leave the work area. Power the unit off and remove the battery and place on the charger, if you have a second battery you can insert it into the device to continue operation. The pulsing alarm will also sound if the battery is overheating. If the unit is operated outside the operating temperature range for 10 minutes the battery alarm will activate. Alarm volume is 85 dBA at 4" (104mm).</p>

BELT REPLACEMENT

FIGURE 9.1

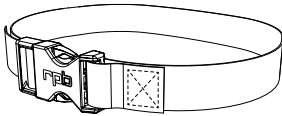

Choose the appropriate belt for the working environment. We offer a variety of belt options for different applications. Refer to the parts list for available belt options.

FIGURE 9.2

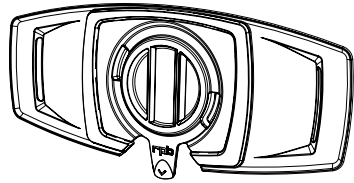

To thread the belt through the support, start with it detached from the PX5®.

FIGURE 9.3

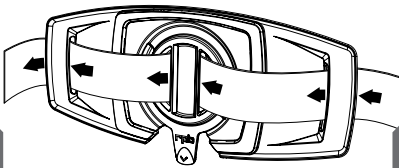

Thread the belt through the belt bracket as shown above, note the orientation.

FIGURE 9.4

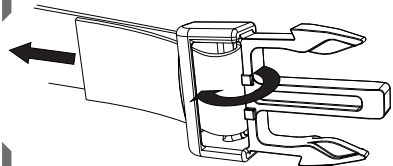

Now thread the clip end of the buckle onto the belt and pull to the desired length in the sequence shown above.

RESPIRATOR SETUP AND CARE CONTINUED

BELT/BACKPACK SUPPORT ATTACHMENT

FIGURE 9.5

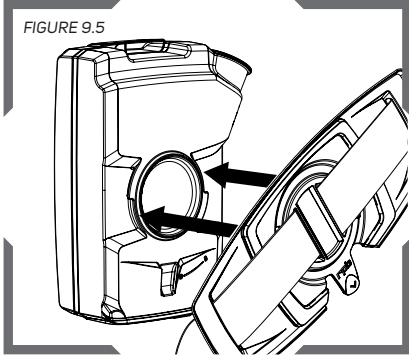

Line up the circular slots of the bracket with the tabs on the back of the PX5®. The locking tab on the belt bracket should be facing towards the bottom.

FIGURE 9.6

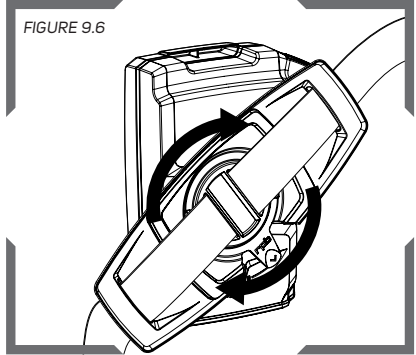

Following the "lock" and "unlock" symbols with the arrow on the belt bracket. Rotate the bracket until the tab clicks over the raised ramp on the back of the PX5®. Check that it is secure.

FLOW METER USE

FIGURE 10.1

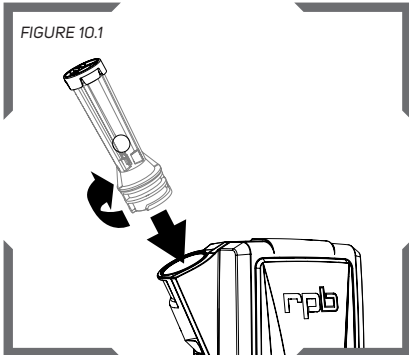

Insert the flow meter into the air outlet. Line up the bayonet slots and turn clockwise 1/2 turn until it locks into place.

FIGURE 10.2

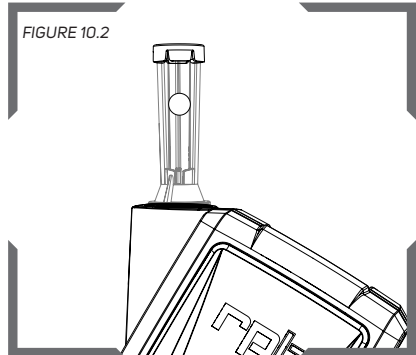

Turn the PX5® unit on and then orientate the unit so the flow meter is pointing straight up or vertical to achieve the most accurate results.

HOW TO READ THE FLOW METER LABEL.

FIGURE 10.3

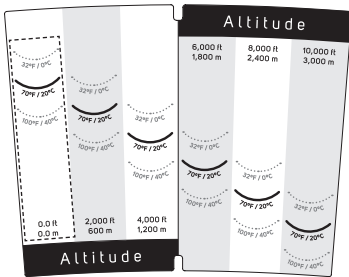

The flow meter levels are grouped by temperature and altitude. Ex.: dashed box shows levels for different temps at 0ft above sea level. Choose the altitude closest to the altitude where the check is being performed.

FIGURE 10.4

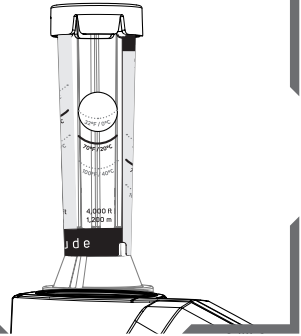

When the PX5® is on speed 1, the ball will float inside the flow meter. Ensure that it sits above the curved line for the altitude and temp for where the check is being performed. Ex: 4,000ft above sea level and 70°F.

Flow Meter Detailed instructions

Determine your location's elevation and the current temperature. Note that these parameters must represent the environment where the air flow check is being conducted, not the work environment the unit is to be used in afterwards. If the environment changes after conducting the air flow test, the unit will automatically adapt to any changes in air pressure or temperature.

Refer to an altimeter or lookup table to determine your location's altitude. Refer to a thermometer to find out the current temperature of your environment. Consult your supervisor if you are uncertain about any of these parameters.

Check the green altitude indications to find the value closest to your location's altitude. Check the temperature markings vertically aligned with that altitude indication to find the one closest to the temperature of your environment. This is the minimum flow rate marker to be checked to. Insert the flow meter into the outlet of the PX5® and rotate 1/2 turn to lock in place. Tilt the PX5® so that the flow meter is vertical. Turn on the PX5® leaving it on Speed 1 and let the air stabilize over a 30 second period. With the meter still in the vertical position check that the ball is sitting above the minimum flow rate marker for your altitude and temperature.

Note that the Airflow Meter is labelled with altitude indications in meters as well as in feet. Temperature indications are printed in °F as well as in °C. Make sure to read the Airflow Meter at the proper units.

Do not use the PX5® if the meter does not reach the minimum airflow rate on the flow meter. Low airflow will decrease the level of protection provided.

RESPIRATOR SETUP AND CARE CONTINUED

INSPECTION, CLEANING AND DISINFECTING

Before each use, the unit should be inspected for the following points. This helps to determine that the unit is operating as it was designed and it is suitably protecting the operator:

1. **PX5® PAPR SYSTEM:** Make a visual inspection of the entire unit, which includes the motor housing, filter door and door cover, filter and pre-filters, battery, belt and breathing tube. Also inspect that an approved hood is attached.
2. **BATTERY PACK:** Check that the battery has full charge to confirm that there is sufficient charge for the work period that you need to accomplish. Make sure that the battery door seal is in good condition and the door is securely closed.
3. **BREATHING TUBE:** Inspect the breathing tube completely, looking for splits and cracks in the tube, the fittings are held securely in the tube and that the seal is in place on the bayonet fitting that inserts into the PX5®. Make sure that the breathing tube fits firmly into the PX5® and seals without any leaks around the connection. See Fig 5.3 and 5.4
4. **HE FILTER:** Inspect the filter casing for cracks and distortions that will affect the seal to the PX5® unit. Inspect the filter paper and the seal carefully for any of the following defects; dirt, cuts and tears, distortions or indentations. The seal can be wiped clean with a damp cloth to remove dirt particles. Do not use solvents or detergents. The HE filter paper must not be cleaned or submersed in water at any time. Damage to the HE filter paper will affect its ability to filter the air and could expose users to harmful environments. All damaged filters, pre-filters and spark arresters must be replaced before using the PX5®.
5. **AIRFLOW METER:** Check the ball in the O3-819 airflow meter is moving freely and that the tube is free of debris.
6. **ALARM SIMULATION:** Check the operation of the airflow alarm is functioning correctly. Power on the PX5® and wait for 5-10 seconds for it to reach nominal flow. Then place the palm of your hand over the outlet on the PX5®. Continuing to hold your hand tightly over the outlet, with the airflow restricted until the alarm sounds, (audible alarm, vibration, and red LED indicator on the User Interface) after 5-10 seconds, indicating that the airflow is below the minimum airflow. Remove your hand and the alarm and LED should return to normal operation once the airflow is back to safe levels.
7. **CLEANING:** The PX5® unit can be cleaned with a damp cloth and diluted mild, pH neutral detergent or diluted isopropyl alcohol (70% IPA or lower) on the external surfaces and the face of the fan motor housing for dirt and contamination. Do not use organic solvents, abrasive cleaners or high percentage ethanol. If you are unsure about the use of cleaning chemicals on the PX5® unit please contact RPB®. The PX5® should not be submersed in water, cleaning solution or placed in a respirator washer. A cleaning kit that allows the PX5® to be submersed will be released at a later date.
8. **BELT SUPPORT BRACKET OR BACKPACK:** Check the Belt Support and belt for cracks, rips, or tears. If cracks or excessive wear is present, they should be replaced. Follow the belt replacement instructions.

STORAGE

The PX5® should not be stored with the filter or battery attached if not being used for long periods of time. Store in a clean and dry environment, away from direct heat sources between 14° F and 114° F (-10° C and +45° C), at a relative humidity of less than 90%.

All batteries must be stored in a cool dry atmosphere. DO NOT store a battery in ambient temperatures that exceed 104°F (40°C). It is recommended that the battery is stored at -4° F to 104° F (-20° C to 40° C) as the optimal temperature range for storage, to maximise the life of the battery.

The battery door should be closed during storage or when the unit is not in use to reduce dust or contaminant ingress.

All filters should be stored in the sealed plastic bag that they came in. Open, unused filters should be stored in an airtight plastic bag or container so that they are not exposed to contamination. Depending on the contaminants, used filters should be placed in an air tight plastic bag so that contaminants are contained and then be disposed of according to regulations.

PRODUCT SPECIFICATIONS AND DATA TABLE 1.2

AIR FLOW	Speed 1: Greater than 6cfm (170slpm). Speed 2: Greater than 7.4cfm (210slpm) Speed 3: Greater than 8.4cfm (240slpm)
OPERATING TEMPERATURE	-4°F to 122°F (-20°C to +50°C). If the unit is operated outside this temperature range for 10 minutes the battery alarm will activate. If the internal battery temperature reaches 140° F (60° C) the unit will completely shut down.
OPERATING NOISE	Speed 1: 57 dBA at 12" (305mm) from the unit. Speed 2: 59 dBA at 12" (305mm) from the unit. Speed 3: 62 dBA at 12" (305mm) from the unit. Note: readings were taken at the distance listed from the front of the unit when connected to a T-Link® Respirator at the 3 speed settings
STORAGE TEMPERATURE	14° F to 113° F (-10° C to 45° C) at a Relevant Humidity of less than 90%. It is recommended that the battery is stored at -4° F to 104° F (-20° C to 40° C) as the optimal temperature range for storage, to maximise the life of the battery.
BATTERY RUN TIMES	Lithium-ion HE Filter Speed 1: 10-13 hours Speed 2: 7-10 hours Speed 3: 6-8 hours Note that these times are estimated from testing using a new battery and new clean filter at 70°F (21°C). These times could be longer or shorter depending on environments and configurations. Note: you should consult with your transport specialist before transporting Lithium-ion batteries.
BATTERY CHARGING	5 hours, 300+ cycles with battery life greater than 80% of original
PRODUCT STORAGE LIFE (from new if kept in original sealed packaging) A. MOTOR/FAN UNIT B. BATTERY PACK C. FILTERS	A. 5 years B. 1 year C. 5 years
INTRINSIC SAFETY	The PX5® PAPR is NOT classed as an Intrinsically Safe Device.
ASSIGNED PROTECTION FACTOR (APF)	The assigned protection factor is dependent on the type of respirator used with the PX5® PAPR.

PARTS AND ACCESSORIES

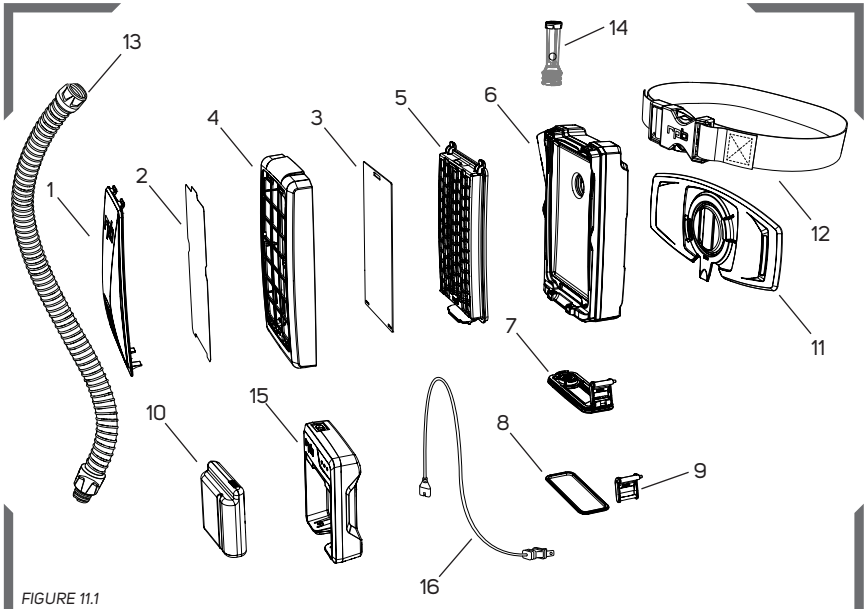

FIGURE 11.1

Item Number	Description	Part Number
1	Cowling	03-812
2	Spark Arrestor	03-891
3	Prefilter (Packet of 10)	03-890
4	HE Filter Door	03-813
5	High Efficiency (HE) Filter	03-892
6	Fan Housing	03-810
7	Battery Door Assembly	03-815
8	Battery Door Seal	03-817
9	Battery Door Hinge (Retainer)	03-818
10	Battery	03-855
11	Belt and Support Bracket	03-811
12	2" Belt Assembly	07-765
	2" Belt Assembly - FR	07-765-FR
13	Breathing Tube	04-831
14	Flow Meter	03-819
15	Battery Charger	03-851
16	Power Cable - USA 2 pin	09-021
	Power Cable - UK 3 pin	09-021-UK
	Power Cable - EU 3 pin	09-021-EU
	Power Cable - AU 2 pin	09-021-AU

⚠ WARNING Use only exact, authentic RPB® replacement parts (marked with the RPB® logo and part number), and only in the specified configuration. Using incomplete or inappropriate equipment, including the use of counterfeit or non-RPB® parts, can result in inadequate protection and will void the NIOSH approval of the entire respirator assembly.

LIMITED WARRANTY

RPB® warrants that its Products will be free from defects in materials and workmanship for one (1) year, subject to the terms of this limited warranty. The Products are sold only for commercial use, and no consumer warranties apply to the Products. This limited warranty is for the benefit of the original Product purchaser, and cannot be transferred or assigned. This is the sole and exclusive warranty provided by RPB®, and ALL CONDITIONS AND IMPLIED WARRANTIES (INCLUDING ANY WARRANTY OF MERCHANTABILITY OR FITNESS FOR A PARTICULAR PURPOSE) ARE EXCLUDED AND DISCLAIMED FROM WARRANTY COVERAGE. RPB's® limited warranty coverage does not apply to damage resulting from accident, improper use or misuse of the Products, wear and tear resulting from the normal use of the Products, or the failure to properly maintain the Products.

RPB's® limited warranty coverage runs from the original date of purchase of the Products, and applies only to warranted defects which first manifest themselves and are reported to RPB® within the warranty period. RPB® retains the right to determine to its reasonable satisfaction whether any claimed defect is covered by this limited warranty.

If a warranted defect occurs, RPB® will repair or replace the defective Product (or a component of the Product), in its sole discretion. This "repair or replacement" remedy is the sole and exclusive remedy under this limited warranty, and under no circumstances shall RPB's® liability under this limited warranty exceed the original purchase price for the Products (or the applicable component). RPB® has no responsibility for incidental or consequential damages, including loss of use, maintenance and other costs, and ALL INCIDENTAL AND CONSEQUENTIAL DAMAGES ARE EXCLUDED AND DISCLAIMED from this limited warranty. Contact RPB® to obtain warranty service. Proof of purchase must be provided to obtain warranty service. All costs of returning the Products to RPB® for warranty service must be paid by the purchaser.

RPB® reserves the right to improve its Products through changes in design or materials without being obligated to purchasers of previously manufactured Products.

LIABILITY

RPB® Safety cannot accept any liability of whatsoever nature arising directly or indirectly from the use or misuse of RPB® Safety products, including purposes that the products are not designed for. RPB® Safety is not liable for damage, loss or expense resulting from the failure to give advice or information or the giving of incorrect advice or information, whether or not due to RPB® Safety's negligence or that of its employees, agents or subcontractors.

NOTES

A series of horizontal dotted lines for writing notes.

OTHER PRODUCTS

RPB® Z-LINK®

The most versatile multi-purpose respirator system on the planet. From welding and grinding to chemical handling, the Z-Link® serves the widest spectrum of industries and applications on the market. This is more than a product. It's a system. Engineered to advance your safety. Designed to increase your productivity.



RPB® T-LINK®

Built off the Z-Link® platform, the T-Link® is designed to work with you, not against you. Gone are the days of having to fight against a Tyvek® respirator. The T-Link® moves with the operator anywhere they turn.



RPB® Z4®

The Z4® is the most advanced welding industrial respirator. Light weight and able to quickly flip up the weld visor for grinding or setting up the next weld while still offering respiratory protection and superior viewing. Designed to protect you for life's best moments.



MAN-73

rpb®